

Logic Design – Tutorial

05

#	Student ID	Student Name	Grade (10)
-			



Q1	<p>Represent each of the following sentences by a Boolean equation.</p> <p>(a) The company safe should be unlocked only when Mr. Jones is in the office or Mr. Evans is in the office, and only when the company is open for business, and only when the security guard is present.</p> <p>(b) You should wear your overshoes if you are outside in a heavy rain and you are wearing your new suede shoes, or if your mother tells you to.</p> <p>(c) You should laugh at a joke if it is funny, it is in good taste, and it is not offensive to others, or if it is told in class by your professor (regardless of whether it is funny and in good taste) and it is not offensive to others.</p> <p>(d) The elevator door should open if the elevator is stopped, it is level with the floor, and the timer has not expired, or if the elevator is stopped, it is level with the floor, and a button is pressed.</p>
Sol 1	<p>(a) U: Safe unlocked, J: Mr. Jones present, E: Mr. Evans present, B: Normal business hours, S: Security guard present $U = (J + E)BS$</p> <p>(b) O: Wear overshoes, A: You are outside, R: Raining heavily, S: Wearing suede shoes, M: Mother tells you to $O = ARS + M$</p> <p>(c) L: Laugh at joke, F: It is funny, G: Good taste, O: Offensive, P: Told by professor $L = FGO' + PO'$</p> <p>(d) D: Elevator door opens, S: Elevator is stopped, F: Level with floor, T: Timer expired, B: Button pressed $D = SFT' + SFB$</p>



Q2

A flow rate sensing device used on a liquid transport pipeline functions as follows.

The device provides a 5-bit output where all five bits are zero if the flow rate is less than 10 gallons per minute. The first bit is 1 if the flow rate is at least 10 gallons per minute; the first and second bits are 1 if the flow rate is at least 20 gallons per minute; the first, second, and third bits are 1 if the flow rate is at least 30 gallons per minute; and so on. The five bits, represented by the logical variables A, B, C, D, and E, are used as inputs to a device that provides two outputs Y and Z.

(a) Write an equation for the output Y if we want Y to be 1 iff the flow rate is less than 30 gallons per minute.

(b) Write an equation for the output Z if we want Z to be 1 iff the flow rate is at least 20 gallons per minute but less than 50 gallons per minute

Sol 2

<i>A B C D E</i>		<i>y</i>	<i>z</i>
0 0 0 0 0	(less than 10 gpm)	+	
1 0 0 0 0	(at least 10 gpm)	+	
1 1 0 0 0	(at least 20 gpm)	+	+
1 1 1 0 0	(at least 30 gpm)		+
1 1 1 1 0	(at least 40 gpm)		+
1 1 1 1 1	(at least 50 gpm)		

(a) $Y = A'B'C'D'E' + AB'C'D'E' + ABC'D'E'$

(b) $Z = ABC'D'E' + ABCD'E' + ABCDE'$



Q3	<p>Each of three coins has two sides, heads and tails. Represent the heads or tails status of each coin by a logical variable (A for the first coin, B for the second coin, and C for the third) where the logical variable is 1 for heads and 0 for tails. Write a logic function $F(A, B, C)$ which is 1 iff exactly one of the coins is heads after a toss of the coins. Express F</p> <p>(a) as a minterm expansion. (b) as a maxterm expansion.</p>
Sol 3	<p>(a) Exactly one variable not complemented: $F = A'B'C + A'BC' + AB'C' = \sum m(1, 2, 4)$</p> <p>(b) Remaining terms are maxterms: $F = \prod M(0, 3, 5, 6, 7) = (A + B + C)(A + B' + C')(A' + B + C')(A' + B' + C)(A' + B' + C')$</p>



Q4

A switching circuit has four inputs as shown. A and B represent the first and second bits of a binary number N_1 . C and D represent the first and second bits of a binary number N_2 . The output is to be 1 only if the product $N_1 \times N_2$ is less than or equal to 2.

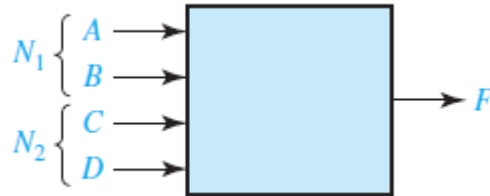

(a) Find the minterm expansion for F .

(b) Find the maxterm expansion for F .

Express your answers in both decimal notation and algebraic form.

Sol 4

$ABCD$		F
0 0 0 0	$0 \times 0 = 0 \leq 2$	1
0 0 0 1	$0 \times 1 = 0 \leq 2$	1
0 0 1 0	$0 \times 2 = 0 \leq 2$	1
0 0 1 1	$0 \times 3 = 0 \leq 2$	1
0 1 0 0	$1 \times 0 = 0 \leq 2$	1
0 1 0 1	$1 \times 1 = 1 \leq 2$	1
0 1 1 0	$1 \times 2 = 2 \leq 2$	1
0 1 1 1	$1 \times 3 = 3 > 2$	0
1 0 0 0	$2 \times 0 = 0 \leq 2$	1
1 0 0 1	$2 \times 1 = 2 \leq 2$	1
1 0 1 0	$2 \times 2 = 4 > 2$	0
1 0 1 1	$2 \times 3 = 6 > 2$	0
1 1 0 0	$3 \times 0 = 0 \leq 2$	1
1 1 0 1	$3 \times 1 = 3 > 2$	0
1 1 1 0	$3 \times 2 = 6 > 2$	0
1 1 1 1	$3 \times 3 = 9 > 2$	0

(a) $F(A, B, C, D) = \sum m(0, 1, 2, 3, 4, 5, 6, 8, 9, 12)$
Refer to FLD p. 695 for full term expansion

(b) $F(A, B, C, D) = \prod M(7, 10, 11, 13, 14, 15)$
Refer to FLD p. 695 for full term expansion

Q5

A combinational logic circuit has four inputs ($A, B, C,$ and D) and one output Z . The output is 1 iff the input has three consecutive 0's or three consecutive 1's. For example, if $A = 1, B = 0, C = 0,$ and $D = 0,$ then $Z = 1,$ but if $A = 0, B = 1, C = 0,$ and $D = 0,$ then $Z = 0.$ Design the circuit using one four-input OR gate and four three-input AND gates.

Sol 5

A	B	C	D	Z
0	0	0	0	1
0	0	0	1	1
0	0	1	0	0
0	0	1	1	0
0	1	0	0	0
0	1	0	1	0
0	1	1	0	0
0	1	1	1	1
1	0	0	0	1
1	0	0	1	0
1	0	1	0	0
1	0	1	1	0
1	1	0	0	0
1	1	0	1	0
1	1	1	0	1
1	1	1	1	1

$$\begin{aligned}
 Z &= A'B'C'D' + A'B'C'D + AB'C'D' \\
 &\quad + ABCD' + ABCD + A'BCD \\
 &= A'B'C' + ABC + AB'C'D' + \\
 &\quad A'BCD \\
 &= A'B'C' + ABC + AB'C'D' + \\
 &\quad A'BCD + \underline{BCD} + \underline{B'C'D'} \\
 &\quad \text{(Added consensus terms)} \\
 \therefore Z &= A'B'C' + ABC + BCD + \\
 &\quad B'C'D'
 \end{aligned}$$

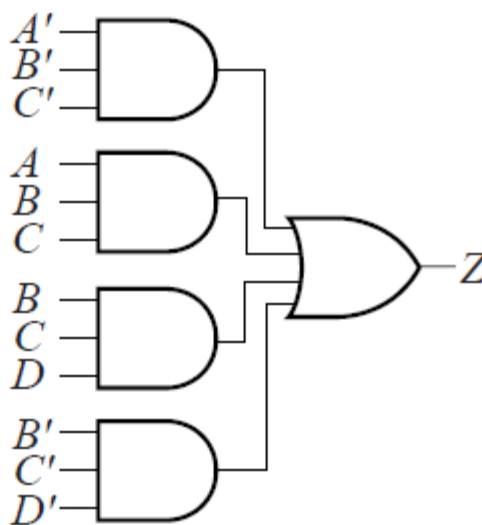

Q6	A bank vault has three locks with a different key for each lock. Each key is owned by a different person. To open the door, at least two people must insert their keys into the assigned locks. The signal lines A , B , and C are 1 if there is a key inserted into lock 1, 2, or 3, respectively. Write an equation for the variable Z which is 1 iff the door should open.
Sol 6	$Z = AB + AC + BC$

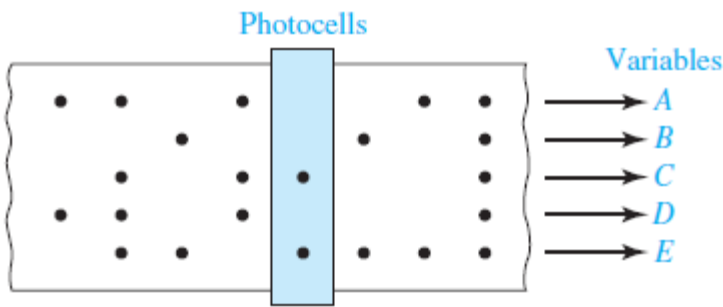
Q7	<p>A paper tape reader used as an input device to a computer has five rows of holes as shown. A hole punched in the tape indicates a logic 1, and no hole indicates a logic 0. As each hole pattern passes under the photocells, the pattern is translated into logic signals on lines A, B, C, D, and E. All patterns of holes indicate a valid character with two exceptions. A pattern consisting of none of the possible holes punched is not used because it is impossible to distinguish between this pattern and the unpunched space between patterns. An incorrect pattern punched on the tape is erased by punching all five holes in that position. Therefore, a valid character punched on the tape will have at least one hole but will not have all five holes punched.</p> <p>(a) Write an equation for a variable Z which is 1 iff a valid character is being read. (b) Write an equation for a variable Y which is 1 iff the hole pattern being read has holes punched only in rows C and E.</p> <div data-bbox="321 987 1039 1291" style="text-align: center;">  <p>The diagram shows a paper tape with five rows of holes. A vertical bar labeled 'Photocells' is positioned over the tape. Arrows labeled 'Variables' point from the photocells to the variables A, B, C, D, and E. The holes are arranged as follows: Row A has holes in columns 1, 2, and 3; Row B has a hole in column 3; Row C has holes in columns 2, 3, and 4; Row D has holes in columns 1, 2, and 3; Row E has holes in columns 1, 2, and 3.</p> </div>
Sol 7	$Z = (ABCDE + A'B'C'D'E)'; Y = A'B'CD'E$



Q8	<p>A computer interface to a line printer has seven data lines that control the movement of the paper and the print head and determine which character to print. The data lines are labeled $A, B, C, D, E, F,$ and $G,$ and each represents a binary 0 or 1. When the data lines are interpreted as a 7-bit binary number with line A being the most significant bit, the data lines can represent the numbers 0 to 127₁₀. The number 13₁₀ is the command to return the print head to the beginning of a line, the number 10₁₀ means to advance the paper by one line, and the numbers 32₁₀ to 127₁₀ represent printing characters.</p> <p>(a) Write an equation for the variable X which is 1 iff the data lines indicate a command to return the print head to the beginning of the line.</p> <p>(b) Write an equation for the variable Y which is 1 iff there is an advance paper command on the data lines.</p> <p>(c) Write an equation for the variable Z which is 1 iff the data lines indicate a printable character. (<i>Hint</i>: Consider the binary representations of the numbers 0–31 and 32–127 and write the equation for Z with only two terms.)</p>
Sol 8	<p>∴ (a) $13_{10} = D_{16} = 00011101; \therefore X = A'B'C'DEF'G$</p> <p>∴ (b) $10_{10} = 0001010; \therefore Y = A'B'C'DE'FG'$</p> <p>∴ (c) $0_{10} = 0000000_2; 64_{10} = 1000000_2; 31_{10} = 0011111_2;$ $127_{10} = 1111111_2; 32_{10} = 0100000_2; \therefore Z = (A'B)' = A + B$</p>