



CS  
IT

# Lecture (07)

## 802.11 protocol releases

---

By:

**Dr. Ahmed ElShafee**

Dr. Ahmed ElShafee, ACU : Spring 2016, Wireless Networks

## Agenda

---

- The 802.11 Protocol Family Overview
- The Original 802.11 Protocol
- The 802.11b Protocol
- The 802.11g Protocol
- 802.11g & 802.11b compatibility
- The 802.11a Protocol
- The 802.11n Protocol

# The 802.11 Protocol Family Overview

---

- The IEEE helps to standardize wireless protocols through 802.11 a/b/g and n protocols.
- These four IEEE standards define the wireless family that is used in almost all wireless LANS today
- Started with the original 802.11 protocol in 1997
- The 802.11 protocols encompass the 2.4-GHz and 5-GHz range.

۳

Dr. Ahmed ElShafee, ACU : Spring 2016, Wireless Networks

## The Original 802.11 Protocol

---

- It is rare to find the original protocol in new hardware today, probably because it only operates at 1 and 2 Mbps.
- Uses frequency-hopping spread spectrum (FHSS), which operates only at 1 and 2 Mbps
- It also describes direct sequence spread spectrum (DSSS), which operates only at 1 and 2 Mbps too.
- If a client operates at any other data rate, it is considered non-802.11 compliant, even if it can use the 1- and 2-Mbps rates.

### *The 802.11 Protocol*

Ratified	1997
RF Technology	FHSS and DSSS
Frequency Spectrum	2.4-GHz

---

# The Original 802.11 Protocol (cont,..)

---

- the industry, scientific, and medical (ISM) bands and operates only in the 2.4-GHz range.
- In the United States, the FCC allows channels 1 through 11 to be used, this gives you 3 non-overlapping channels: 1, 6, and 11.
- European ETSI allows using 13 channels
- In Japan, 14 channels are allowed.
  
- The 2.4-GHz range has up to 14 channels.

o

Dr. Ahmed ElShafee, ACU : Spring 2016, Wireless Networks

## The 802.11b Protocol

---

- 802.11b is a supplement to the 802.11 protocol
- As technology moves faster than the standards do, Vendors developed methods of achieving higher data rates.
- The danger in vendor-designed protocols, of course, is *interoperability*.
- *The job of the IEEE was simply to define a standard that all vendors could follow based on the proprietary implementations that they were using.*
- 802.11b offers higher data rates—up to 11 Mbps—with backward compatibility at 1 and 2 Mbps.

7

Dr. Ahmed ElShafee, ACU : Spring 2016, Wireless Networks

# The 802.11b Protocol (cont,..)

---

- At 1 and 2 Mbps (802.11), the same coding and modulation as 802.11 is used (Barker 11 coding), & (differential binary phase-shift keying (DBPSK)).
- When operating at the new speeds—5.5 Mbps and 11 Mbps (802.11b)—a different modulation and coding is used (complementary code keying (CCK)), & (differential quadrature phase-shift keying (DQPSK)), the result is more data sent in the same period).
- 802.11b was ratified in September 1999.
- The United States has 11 channels, in Europe, the ETSI defines 13 channels, and Japan has 14

v

Dr. Ahmed ElShafee, ACU : Spring 2016, Wireless Networks

# The 802.11b Protocol (cont,..)

---

- 802.11b allows dynamic rate shifting (DRS) to enable clients to shift rates to lower rates as they travel farther away from an AP and higher rates as they get closer to an AP.
- Today, 802.11b is the most popular and most widely deployed wireless standard.

## *The 802.11b Protocol*

Ratified	1999
RF Technology	DSSS
Frequency Spectrum	2.4-GHz
Coding	Barker 11 and CCK
Modulation	DBPSK and DQPSK
Data Rates	1, 2, 5.5, 11 Mbps
Nonoverlapping Channels	1, 6, 11

# The 802.11g Protocol

---

- The IEEE ratified 802.11g in June 2003
- It added eight more data rates, the maximum data rate of 54 Mbps;
- 802.11g is still compatible with 802.11b, using the same modulation and coding as 802.11b for the 1-, 2-, 5.5-, and 11-Mbps rates.
- To achieve the higher data rates, 802.11g uses orthogonal frequency division multiplexing (OFDM) for modulation.
- still only three non-overlapping channels.

## The 802.11g Protocol (cont,..)

---

### *The 802.11g Protocol*

Ratified	June 2003
RF Technology	DSSS and OFDM
Frequency Spectrum	2.4 GHz
Coding	Barker 11 and CCK
Modulation	DBPSK and DQPSK
Data Rates	1, 2, 5.5, 11 Mbps with DSSS 6, 9, 12, 18, 24, 36, 48, 54 Mbps with OFDM
Nonoverlapping Channels	1, 6, 11

---

# 802.11g & 802.11b compatibility

---

- 802.11g is backward compatible with 802.11b clients.
- But to support 802.11b clients, the entire cell suffers.
- The cell performance could degrade.
- This degradation in performance is because 802.11b clients mis-understand OFDM.
- If an 802.11b client sends when an 802.11g client is sending, a collision will occur, and both clients will have to resend (CSMA/CA is useless here).
- However, protection mechanisms are built in.

11

Dr. Ahmed ElShafee, ACU : Spring 2016, Wireless Networks

## 802.11g & 802.11b compatibility (cont,..)

---

1. Assume that initially 802.11b clients do not exist.
  - The default behavior of an AP is to send beacons that include information about the AP and the wireless cell.
  - Without 802.11b clients, the AP sends the following information in a beacon:
    - **NON ERP present: no**
    - **Use Protection: no**

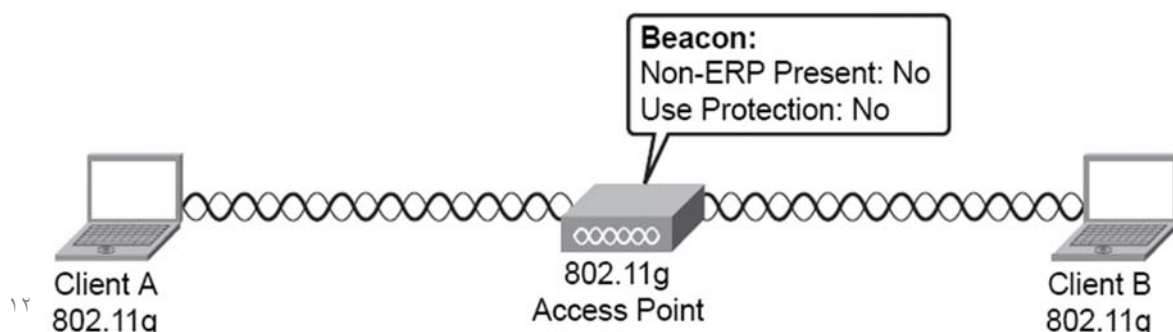

12

## 802.11g & 802.11b compatibility (cont,..)

---

- ERP is Extended Rate Physical, which means that these are devices that have extended data rates
- NON\_ERP is talking about 802.11b clients
- So
- NON ERP present: no (802.11g)
- NON ERP present: yes (802.11b)

## 802.11g & 802.11b compatibility (cont,..)

---

- the AP tells everyone that 802.11b clients are unavailable and that they do not need to use protection mechanisms.

## 802.11g & 802.11b compatibility (cont,..)

---

2. After an 802.11b client associates with the AP,

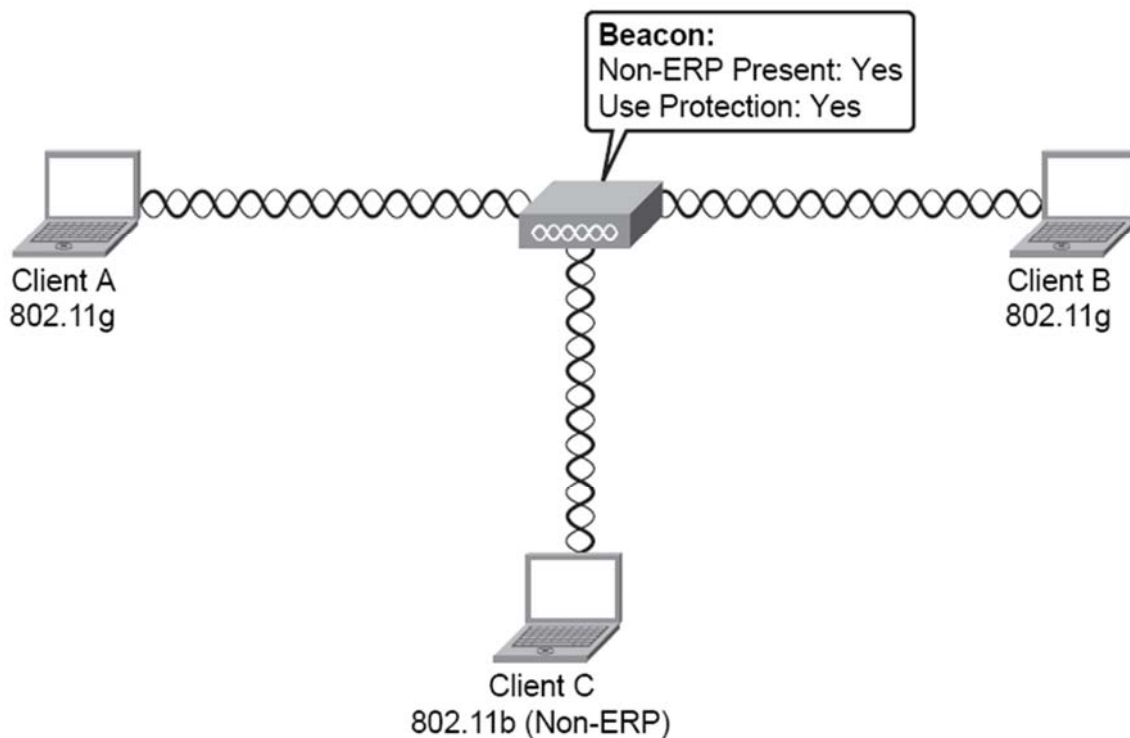

10

## 802.11g & 802.11b compatibility (cont,..)

---

- the AP alerts the rest of the network about the NON\_ERP client, this is done in the beacon that the AP sends.
- **NON ERP present: yes**
- **Use Protection: yes**

11



# 802.11g & 802.11b compatibility (cont,..)

3. When an 802.11g client sends a frame, it first must warn the 802.11b clients.

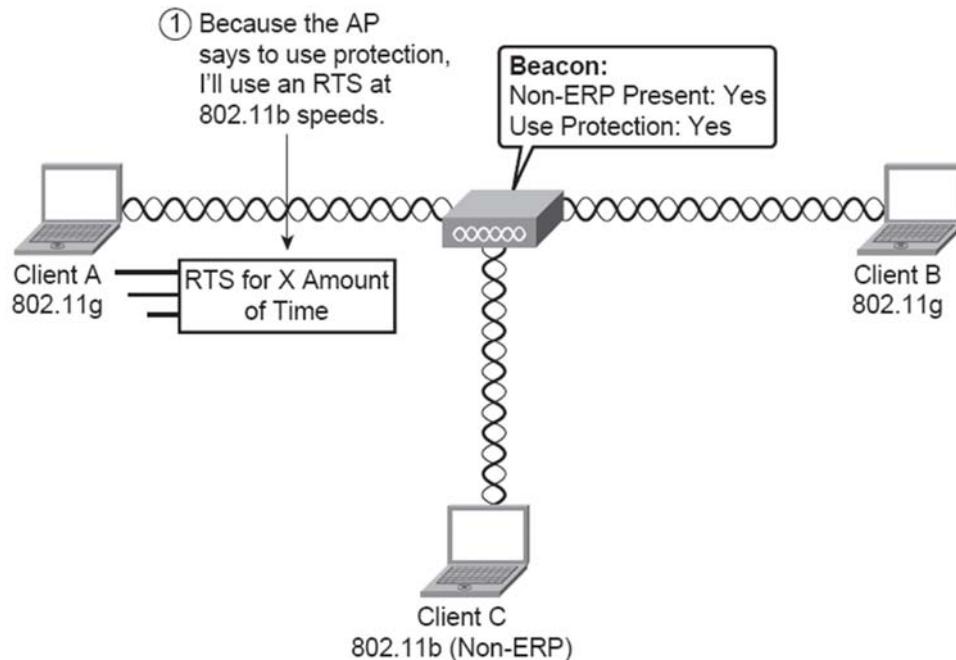

17

# 802.11g & 802.11b compatibility (cont,..)

- by sending a request to send (RTS) message at 802.11b speed so the 802.11b clients can hear and understand it.
- The RTS is a unicast that is sent to the recipient of the frame that the 802.11g client wants to send to.

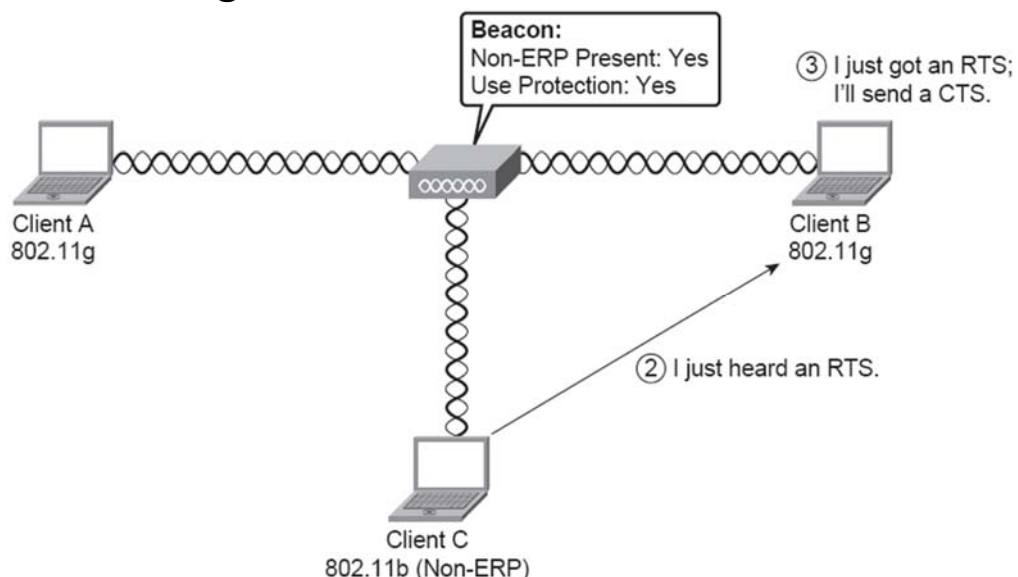

18

# 802.11g & 802.11b compatibility (cont,..)

4. The recipient then responds with a clear to send (CTS) at 802.11b speed.

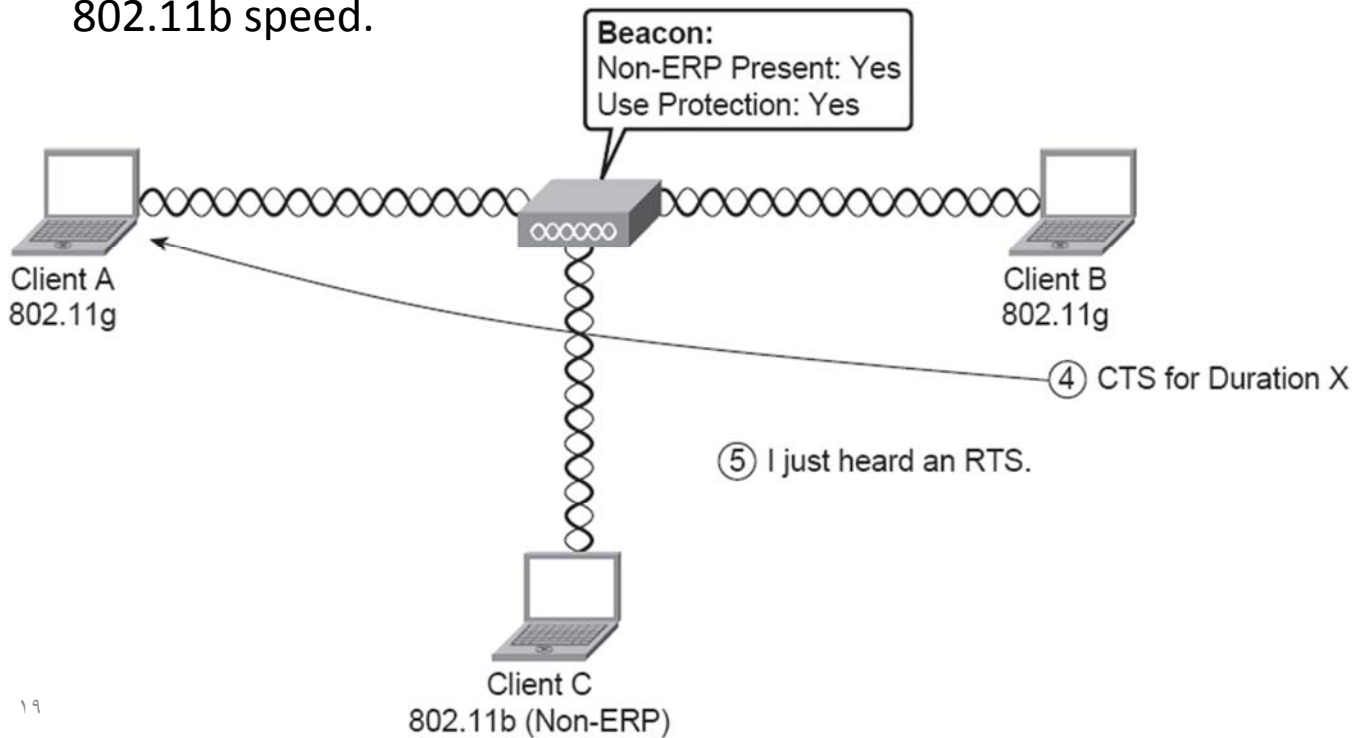

# 802.11g & 802.11b compatibility (cont,..)

- Client A sends data to Client B at 802.11g speeds

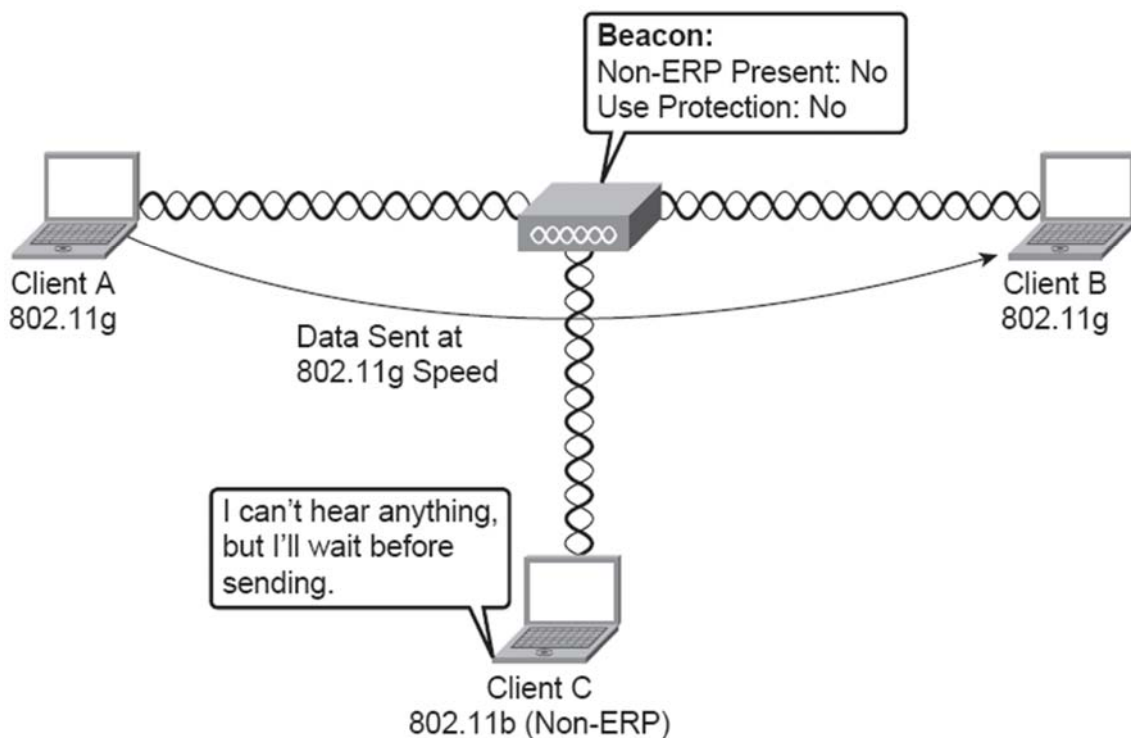

## 802.11g & 802.11b compatibility (cont,..)

---

- (Client C) cannot hear the data that it perceived as noise, but it still waits the duration seen in the RTS/CTS before sending data.

## 802.11g & 802.11b compatibility (cont,..)

---

- bad side effect of 802.11b clients in an 802.11g cell is sort of a domino effect.
- As one AP advertises:
- **NON ERP present: yes**
- **Use Protection: yes**
- Nearby APs that hear this beacon start to advertise:
- **NON ERP present: no**
- **Use Protection: yes**
- The nearby cell advertises NON\_ERP present to indicate that it did not hear NON\_ERP devices, yet it advertises “**Use Protection: yes**” to be safe.

# 802.11g & 802.11b compatibility (cont,..)

---

- This in effect forces the cell to use protection even without 802.11b clients in that particular cell, thus degrading performance for everyone in the cell.
- This is why APs have the option to use 802.11g only.

# The 802.11a Protocol

---

- 802.11a was ratified in 1999 and operates in the 5-GHz frequency range
- Why? To avoid interference from other 2.4 GHz devices, like, Bluetooth devices, and cordless phones
- it is incompatible with 802.11, 802.11b, and 802.11g,
- 802.11a had late-market adoption, so it is not as widely deployed as the 802.11b and g protocols.
- 802.11a supports anywhere from 12 to 23 non-overlapping channels as opposed to the 3 non-overlapping channels in 802.11b/g.

## The 802.11a Protocol (cont,..)

---

- 802.11a requires that the data rates of 6, 12, and 24 Mbps be supported but allows for data rates up to 54 Mbps.

### *The 802.11a Protocol*

Ratified	1999
RF Technology	OFDM
Frequency Spectrum	5.0 GHz
Coding	Convolution Coding
Modulation	BPSK, QPSK, 16-QAM, 64-QAM depending on the subcarrier.
Data Rates	6, 9, 12, 18, 24, 36, 48, 54 Mbps with OFDM
Nonoverlapping Channels	from 12 to 23 nonoverlapping

## The 802.11a Protocol (cont,..)

---

- Convolution coding is a form of error correction in which redundant information analogous to a parity bit in a file system is added to the data.

# The 802.11a Protocol (cont,..)

---

## 5GHz sub-bands

- What makes 802.11a unique is the way the 5-GHz frequency band (Unlicensed National Information Infrastructure (UNII)) is divided into multiple parts were designed for different uses.
- UNII-1 was designed for indoor use with a permanent antenna.
- UNII-2 was designed for indoor or outdoor use with an external antenna, and
- UNII-3 was designed for outdoor bridges and external antennas.
- **The Non-overlapping Channels Each band has a 4; the middle 8 are used with 52 subcarriers on each channel.**

٢٧

Dr. Ahmed ElShafee, ACU : Spring 2016, Wireless Networks

# The 802.11a Protocol (cont,..)

---

- FCC uses the three different sub-bands, while ETSI allows only the first two sub-bands

*The UNII Frequency Bands*

Band	Frequency	Use
UNII-1	5.15–5.25 GHz (UNII Indoor)	FCC allows indoor and outdoor use.
UNII-2	5.25–5.35 GHz (UNII Low)	Outdoor/indoor with DFC and TPC
UNII-3	5.725–5.825 GHz (U-NII/ISM)	FCC allows indoor and outdoor use. ETSI does not allow unlicensed use.

- In the 802.11a spectrum, the higher-band channels are 30 MHz apart. This includes UNII- 2 and above. The lower bands are 20 MHz apart.

٢٨

Dr. Ahmed ElShafee, ACU : Spring 2016, Wireless Networks

# The 802.11a Protocol (cont,..)

---

## Other Techniques

- Both ETSI and FCC requires the following techniques to be used:
  - dynamic frequency control (DFC)
  - transmit power control (TPC)

# The 802.11a Protocol (cont,..)

---

## 802.11a Power Requirements

*FCC Regulations on Output and EIRP for UNII*

<b>Band</b>	<b>Output Power Not to Exceed</b>	<b>EIRP Maximum</b>
UNII-1	50 mW	22 dBm
UNII-2	250 mW	29 dBm
UNII-2 Extended	1 W	36 dBm
UNII-3	1W	36 dBm

# The 802.11a Protocol (cont,..)

---

## *ETSI Regulations on Output and EIRP for UNII*

<b>Band</b>	<b>Output Power Not to Exceed</b>	<b>EIRP Maximum</b>
UNII-1	200 mW	23 dBm
UNII-2	200 mW	23 dBm
UNII-2 Extended	1 W	30 dBm
UNII-3	Licensed use only	—

# The 802.11n Protocol

---

- Technology has progressed more rapidly than the standards, because vendors are already shipping 802.11n APs and clients.
- you can get speeds up to 300 Mbps, but most documentation says it will provide 100 Mbps, this is probably because the expectation is that other 802.11 clients will be present.
- 802.11n is, backward compatible with 802.11b/g and a.
- its use of multiple antennas and a technology called Multiple-Input.
- MIMO, uses different antennas to send and receive, thus increasing throughput and accomplishing more of a full duplex operation.



# The 802.11n Protocol (cont,..)

---

MIMO comes in three types:

- Pre-coding
- Spatial multiplexing
- Diversity coding

# The 802.11n Protocol (cont,..)

---

## **Pre-Coding**

- Precoding is a function that takes advantage of multiple antennas and the multipath.
- 802.11n uses transmit beamforming (TxBF), which is a technique that is used when more than one transmit antenna exists where the signal is coordinated and sent from each antenna so that the signal at the receiver is dramatically improved, even if it is far from the sender.
- This technique is something that you would use when the receiver has only a single antenna and is not moving.
- If the receiver is moving, then the reflection characteristics change, and the beamforming can no longer be coordinated.

# The 802.11n Protocol (cont,..)

---

## **Spatial multiplexing**

- takes a signal, splits it into several lower rate streams, and then sends each one out of different antennas.
- Each one of the lower rate streams are sent on the same frequency.
- The number of streams is limited to the lowest number of antennas on either the transmitter or the receiver.
- If an AP has four antennas and a client has two, you are limited to two.

# The 802.11n Protocol (cont,..)

---

## **Diversity coding**

MIMO-OFDM systems are able to create parallel channels in space and frequency domains.

However, high-data-rate space and frequency multiplexing are prone to independent parallel channel fades, leading to poor performance unless available diversity is properly exploited.

diversity-coded MIMO-OFDM is an invented coding method for MIMO-OFDM systems,

This method increases reliability without lowering the transmission rate, at a cost of modest processing complexity and delay.

# The 802.11n Protocol (cont,..)

---

## Generally, 802.11n distinct in

1. its physical layer, as signal is sent considers reflections and interferences as an advantage instead of a problem
2. throughput is increased is by aggregation of channels, like two channels are aggregated to increase throughput.
  - 802.11n uses 20-MHz and 40-MHz channels. The 40-MHz channels in 802.11n are actually two 20-MHz channels that are adjacent to each other and bonded.
3. Uses OFDM, which enables the use of more subcarriers that range from 48 to 52.
4. With 802.11n, you can get up to 32 data rates.

# The 802.11n Protocol (cont,..)

---

## block acknowledgments

- it uses block acknowledgments as opposed to acknowledging each unicast packet like the other 802.11 protocols do.
- A block acknowledgment works by sending a number of frames before having them acknowledged.
- This is similar to the way TCP works.

# The 802.11n Protocol (cont,..)

---

## interframe space

- Each sending station must wait until a frame is sent before sending the next frame;
- this is called distributed interframe space (DIFS).
- This DIFS can cause more overhead than necessary.
- 802.11n improves on this DIFS mechanism by using a smaller interframe space called reduced interframe space (RIFS).
- This reduces delay and overhead.

# The 802.11n Protocol (cont,..)

---

## Antenna Considerations

The number of antennas that the sender and the receiver have can differ.

- If a transmitter can emit over three antennas, it has three data streams.
- If it can receive over three antennas, it has three receive chains.
- In documentation, this is called a  $3 \times 3$ .
- Two receive chains and two data streams is called a  $2 \times 2$ .

# The 802.11n Protocol (cont,..)

---

- If you have 2×3 AP device, and 2x2 laptop
- When using special multiplexing, you are limited to the same number of streams as the lowest number of antennas.
- In this scenario, you would have two streams.
- Finally, note that even if you do not have 802.11n clients, you can expect to see about a 30 percent improvement, based on these features.



**Thanks,..**  
**See you next week (ISA),...**