



# Lecture (06) Capacitance, Dielectrics, Electric Energy Storage

By:

**Dr. Ahmed ElShafee**

Dr. Ahmed ElShafee, ACU : Spring 2015, Physics II

- Capacitors come in a wide range of sizes and shapes, only a few of which are shown here.
- A capacitor is basically two conductors that do not touch, and which therefore can store charge of opposite sign on its two conductors.
- Capacitors are used in a wide variety of circuits

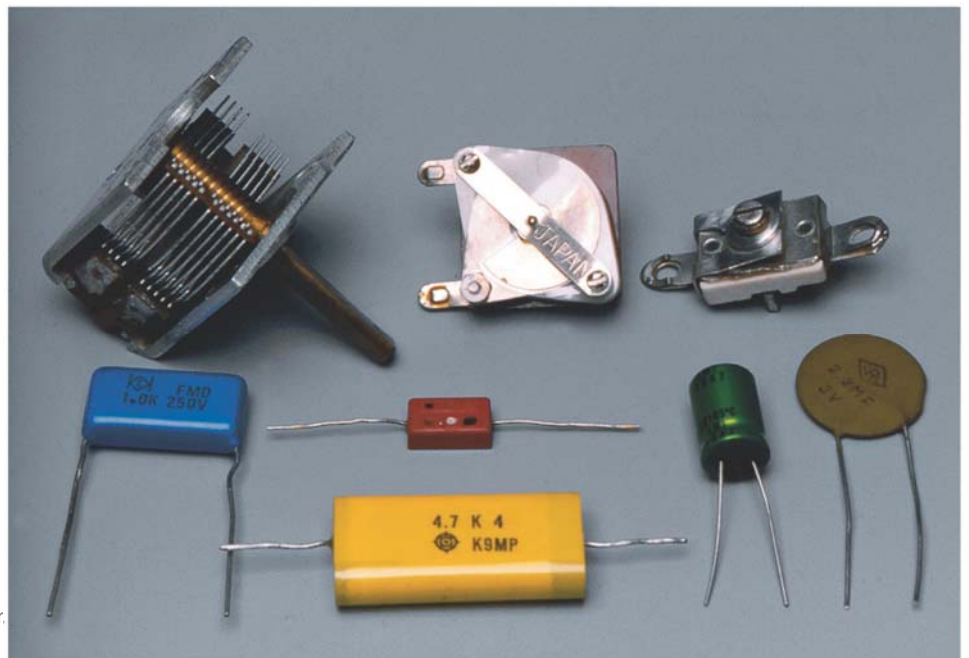

- A capacitor is basically two parallel conducting plates with insulating material in between. The capacitor doesn't have to look like metal plates.

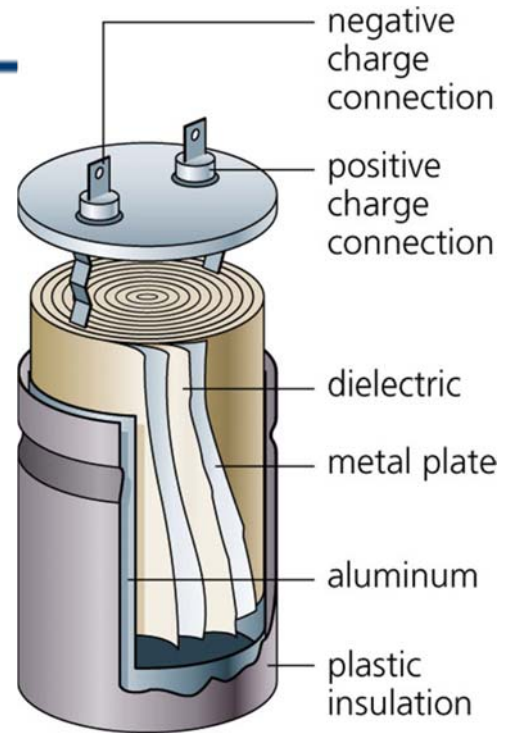

۳

Dr. Ahmed ElShafee, ACU : Spring 2015, Physics II

- When a capacitor is connected to an external potential, charges flow onto the plates and create a potential difference between the plates.

### 3. Capacitors in circuits

– symbols  $\text{—}||\text{—}$   $\text{—}|(\text{—}$

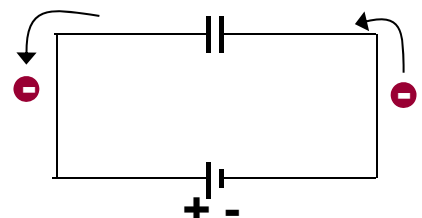

۴

Dr. Ahmed ElShafee, ACU : Spring 2015, Physics II

- The capacitance,  $C$ , of a capacitor is defined as a ratio of the magnitude of a charge on either conductor to the magnitude of the potential difference between the conductors
- $C = \frac{Q}{\Delta V}$

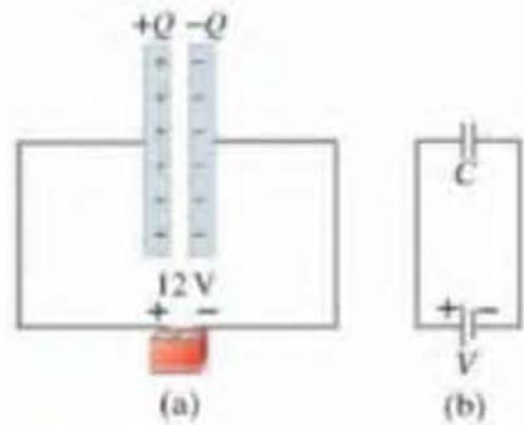

Dr. Ahmed ElShafee, ACU : Spring 2015, Physics II

- The unit of  $C$  is the farad (F), but most capacitors have values of  $C$  ranging from picofarads to microfarads ( $\text{pF}$  to  $\mu\text{F}$ ).
- $1 \text{ F} = 1 \frac{\text{C}}{\text{V}}$
- Recall, micro  $\Rightarrow 10^{-6}$ , nano  $\Rightarrow 10^{-9}$ , pico  $\Rightarrow 10^{-12}$
- If the external potential is disconnected, charges remain on the plates, so capacitors are good for storing charge (and energy).



Dr. Ahmed ElShafee, ACU : Spring 2015, Physics II

# MCQ

---

- Capacitor  $C_1$  is connected across a battery of 5 V. An identical capacitor  $C_2$  is connected across a battery of 10 V. Which one has more charge?
- 1)  $C_1$
- 2)  $C_2$
- 3) both have the same charge
- 4) it depends on other factors

v

Dr. Ahmed ElShafee, ACU : Spring 2015, Physics II

# MCQ

---

- Capacitor  $C_1$  is connected across a battery of 5 V. An identical capacitor  $C_2$  is connected across a battery of 10 V. Which one has more charge?
- 1)  $C_1$
- 2)  $C_2$
- 3) both have the same charge
- 4) it depends on other factors

Since  $Q = CV$  and the two capacitors are identical, the one that is connected to the **greater voltage** has more **charge**, which is

$C_2$  in this case.

^

Dr. Ahmed ElShafee, ACU : Spring 2015, Physics II

- The capacitance of a device depends on the geometric arrangement of the conductors
- $C = \epsilon_0 \frac{A}{d}$
- where  $A$  is the area of one of the plates,  $d$  is the separation,  $\epsilon_0$  is a constant called the permittivity of free space,
- $\epsilon_0 = 8.85 \times 10^{-12} \text{ C}^2/\text{N}\cdot\text{m}^2$

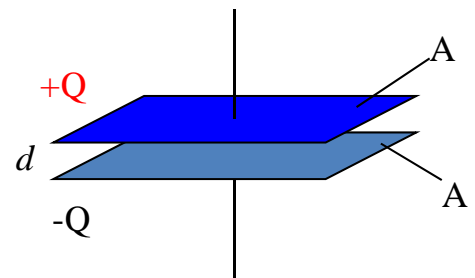

9

Dr. Ahmed ElShafee, ACU : Spring 2015, Physics II

## MCQ

What must be done to a capacitor in order to increase the amount of charge it can hold (for a constant voltage)?

- 1) increase the area of the plates
- 2) decrease separation between the plates
- 3) decrease the area of the plates
- 4) either (1) or (2)
- 5) either (2) or (3)

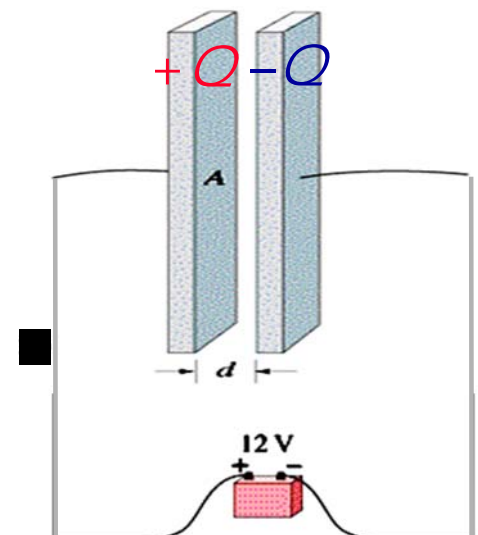

10

Dr. Ahmed ElShafee, ACU : Spring 2015, Physics II

# MCQ

What must be done to a capacitor in order to increase the amount of charge it can hold (for a constant voltage)?

- 1) increase the area of the plates
- 2) decrease separation between the plates
- 3) decrease the area of the plates
- 4) either (1) or (2)
- 5) either (2) or (3)

Since  $Q = CV$ , in order to increase the charge that a capacitor can hold at constant voltage, one has to increase its capacitance. Since the capacitance is

$$\text{given by } C = \epsilon_0 \frac{A}{d}$$

, that can be done by either increasing  $A$  or decreasing  $d$ .

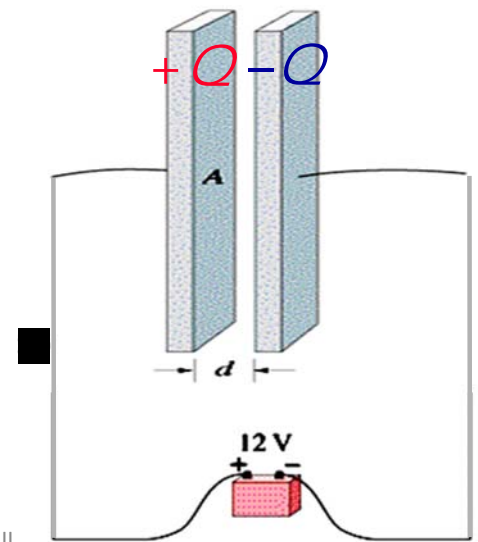

۱۱

Dr. Ahmed ElShafee, ACU : Spring 2015, Physics II

## Example 01

- A parallel plate capacitor has plates  $2.00 \text{ m}^2$  in area, separated by a distance of  $5.00 \text{ mm}$ . A potential difference of  $10,000 \text{ V}$  is applied across the capacitor. Determine
  - the capacitance
  - the charge on each plate

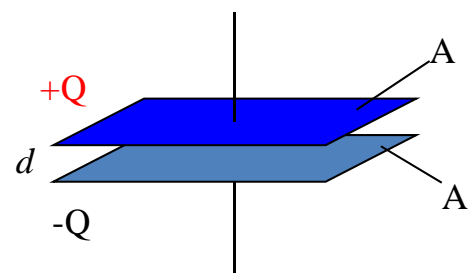

۱۲

Dr. Ahmed ElShafee, ACU : Spring 2015, Physics II

---

- $C = \epsilon_0 \frac{A}{d} = 8.85 \times 10^{-12} \times \frac{2}{5 \times 10^{-3}}$

- $C = 3.54 \times 10^{-9} = 3.54 \text{ nF}$

- $C = \frac{Q}{\Delta V}$

- $Q = C \times \Delta V = 3.54 \times 10^{-9} \times 10000 = 3.54 \times 10^{-5} \text{ C}$

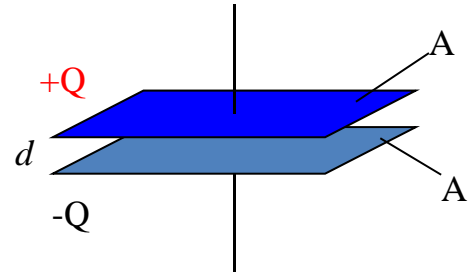

---

## Example 02

- (a) Calculate the capacitance of a parallel-plate capacitor whose plates are 20 cm X 3.0 cm and are separated by a 1.0-mm air gap.
- (b) What is the charge on each plate if a 12-V battery is connected across the two plates?
- (c) What is the electric field between the plates?
- (d) Estimate the area of the plates needed to achieve a capacitance of 1F given the same air gap  $d$ .



a)

$$A = 0.2 \times 0.03 = 0.006 \text{ m}^2$$

$$C = \epsilon_0 \frac{A}{d} = 8.85 \times 10^{-12} \times \frac{0.006}{1 \times 10^{-3}} = 53 \text{ pf}$$

b)

$$Q = C V = 53 \times 10^{-12} \times 12 = 6.64 \times 10^{-10} \text{ C}$$

c)

$$E = \frac{V}{d} = \frac{12}{10^{-3}} = 1.2 \times 10^4 \text{ V/m}$$

d)

$$C = 1F$$

$$A = \frac{C d}{\epsilon_0} = \frac{1 \times 10 \times 10^{-3}}{8.85 \times 10^{-12}} = 10^8 \text{ m}^2$$

## Example 03

- Two circular plates of radius 5.0 cm are separated by a 0.10-mm air gap. What is the magnitude of the charge on each plate when connected to a 12-V battery?

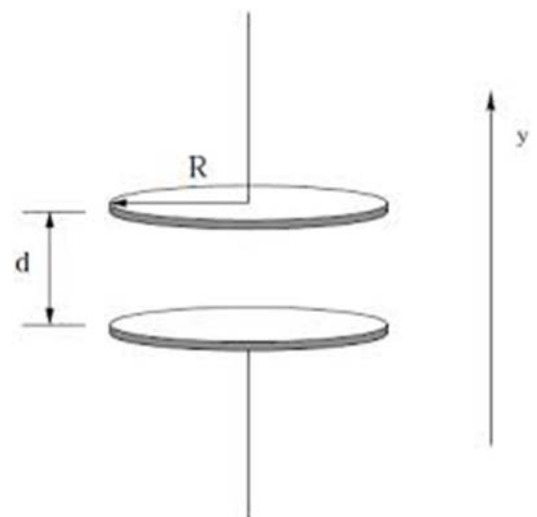



$$A = \pi r^2 = 3.14 \times 0.05^2 = 7.85 \times 10^{-3} \text{ m}^2$$

$$C = \epsilon_0 \frac{A}{d} = 8.85 \times 10^{-12} \times \frac{7.85 \times 10^{-3}}{0.1 \times 10^{-3}} = 6.95 \times 10^{-10} \\ = 0.695 \text{ nF}$$

$$Q = C V = 6.95 \times 10^{-10} \times 12 = 8.34 \times 10^{-9} \text{ C}$$

## Example 04

- A cylindrical capacitor consists of a cylinder (or wire) of radius  $R_b$  surrounded by a coaxial cylindrical shell of inner radius  $R_a$
- Both cylinders have length  $l$  which we assume is much greater than the separation of the cylinders,  $R_b - R_a$ , so we can neglect end effects.
- The capacitor is charged (by connecting it to a battery) so that one cylinder has a charge  $+Q$  (say, the inner one) and the other one a charge  $-Q$ .
- Determine a formula for the capacitance.

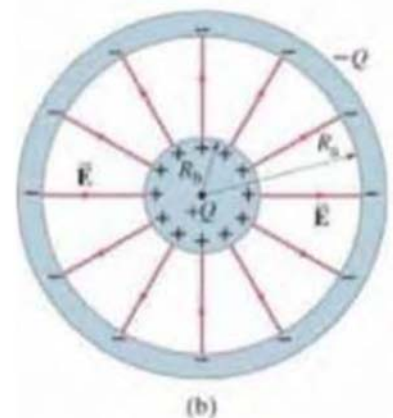
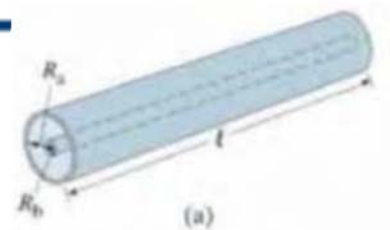

# From lecture 3, calculating E from a wire

- $E_y = 0$  due to symmetry
- $E_x = E \cos \theta$
- $dE_x = k \frac{dq}{r^2} \cos \theta$
- $dq = \lambda dy$  &  $r^2 = x^2 + y^2$
- $dE_x = k \frac{\lambda \cos \theta dy}{x^2 + y^2}$
- $\cos \theta = \frac{x}{(x^2 + y^2)^{1/2}} \rightarrow \frac{1}{x^2 + y^2} = \frac{\cos \theta^2}{x^2}$
- $dE_x = \frac{k \lambda \cos \theta^3 dy}{x^2}$

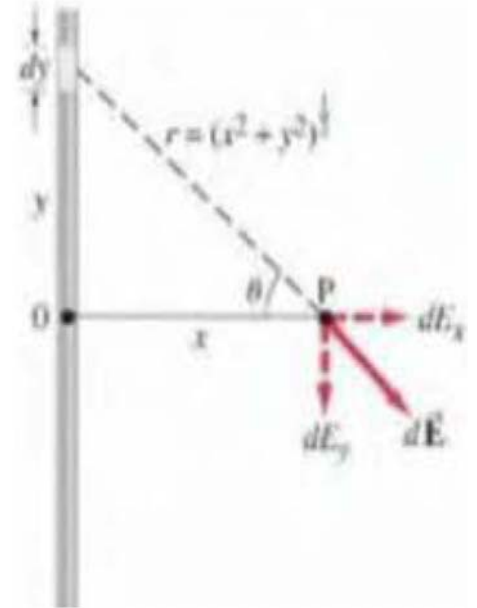

١٩

Dr. Ahmed ElShafee, ACU : Spring 2015, Physics II

- $\tan \theta = \frac{y}{x} \rightarrow y = x \tan \theta$
  - $dy = x d\theta \sec^2 \theta = \frac{x}{\cos^2 \theta} d\theta$
  - as  $dE_x = \frac{k \lambda \cos \theta^3 dy}{x^2} \frac{x}{\cos \theta^2} d\theta$
  - $dE_x = \frac{k \lambda \cos \theta d\theta}{x}$
  - $E_x = \frac{k \lambda}{x} \int_{-\frac{\pi}{2}}^{\frac{\pi}{2}} \cos \theta d\theta$
  - $E_x = \frac{k \lambda}{x} \left( \sin \frac{\pi}{2} - \sin \frac{-\pi}{2} \right) = 2 \frac{k \lambda}{x}$
  - $E_x = \frac{\lambda}{2 \pi \epsilon_0 x} = \frac{Q}{2 \pi \epsilon_0 x l}$
- $\tan \theta = \frac{y}{x} \rightarrow y = x \tan \theta$
  - $dy = x d\theta \sec^2 \theta = \frac{x}{\cos^2 \theta} d\theta$
  - as  $dE_x = \frac{k \lambda \cos \theta^3 dy}{x^2} \frac{x}{\cos \theta^2} d\theta$
  - $dE_x = \frac{k \lambda \cos \theta d\theta}{x}$
  - $E_x = \frac{k \lambda}{x} \int_{-\frac{\pi}{2}}^{\frac{\pi}{2}} \cos \theta d\theta$
  - $E_x = \frac{k \lambda}{x} \left( \sin \frac{\pi}{2} - \sin \frac{-\pi}{2} \right) = 2 \frac{k \lambda}{x}$
  - $E_x = \frac{\lambda}{2 \pi \epsilon_0 x} = \frac{Q}{2 \pi \epsilon_0 x l}$

٢٠

Dr. Ahmed ElShafee, ACU : Spring 2015, Physics II

- $E_r = \frac{\lambda}{2\pi\epsilon_0 r} = \frac{Q}{2\pi\epsilon_0 r l}$
- $V = -\int_a^b E dr = \frac{-Q}{2\pi\epsilon_0 r l} \int_{r_a}^{r_b} \frac{1}{r} dr$
- $V = \frac{-Q}{2\pi\epsilon_0 r l} \ln \frac{r_b}{r_a} = \frac{Q}{2\pi\epsilon_0 r l} \ln \frac{r_a}{r_b}$
- $C = \frac{Q}{V} = \frac{2\pi\epsilon_0 r l}{\ln(r_a/r_b)}$

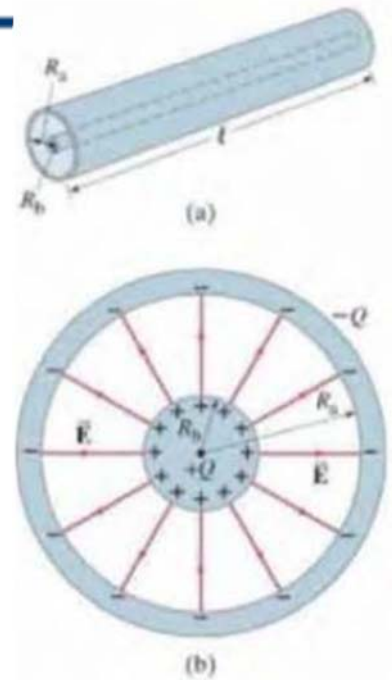

## Example 05

- A spherical capacitor consists of two thin concentric spherical conducting shells, of radius  $r_a$  and  $r_b$
- The inner shell carries a uniformly distributed charge  $Q$  on its surface.
- and the outer shell an equal but opposite charge  $-Q$ .  
Determine the capacitance of the two shells.

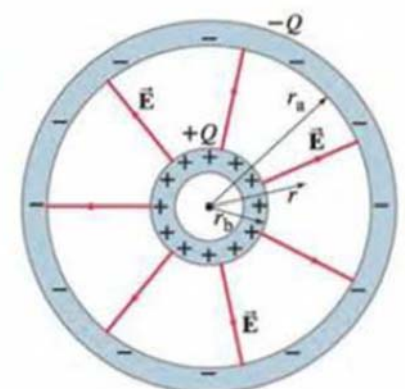

- $V_{ba} = - \int_a^b E dl = - \frac{Q}{4 \pi \epsilon_0} \int_{r_a}^{r_b} \frac{1}{r^2} dr$
- $V_{ba} = \frac{Q}{4 \pi \epsilon_0} \left( \frac{1}{r_b} - \frac{1}{r_a} \right) = \frac{Q}{4 \pi \epsilon_0} \frac{r_a - r_b}{r_b r_a}$
- $C = \frac{Q}{V} = 4 \pi \epsilon_0 \frac{r_a r_b}{r_a - r_b}$

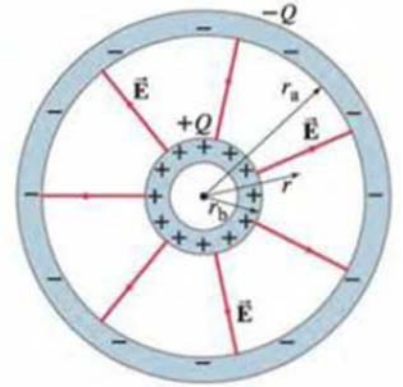

## Example 06

- Estimate the capacitance per unit length of two very long straight parallel wires, each of radius  $R$ , carrying uniform charges  $+Q$  and  $-Q$ , and separated by a distance  $d$  which is large compared to  $R$  ( $d \gg R$ ),

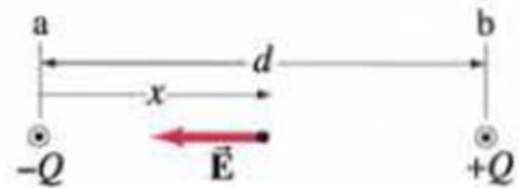

# From lecture 3, calculating E from a wire

- $E_x = \frac{\lambda}{2\pi\epsilon_0 x} = \frac{Q}{2\pi\epsilon_0 x l}$

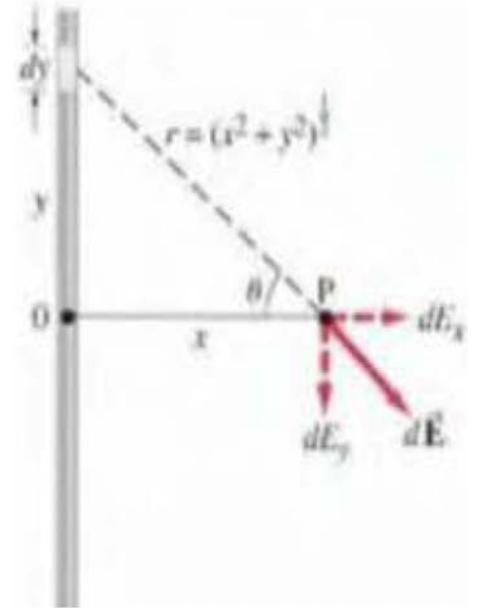

٢٥

Dr. Ahmed ElShafee, ACU : Spring 2015, Physics II

- $E = \frac{Q}{2\pi\epsilon_0 x l} + \frac{Q}{2\pi\epsilon_0 (d-x) l}$
- $V = -\int_a^b E dl = \frac{Q}{2\pi\epsilon_0 l} \int_R^{d-R} \left[ \frac{1}{x} + \frac{1}{d-x} \right] dx$
- $V = \frac{Q}{2\pi\epsilon_0 l} (\ln(x) - \ln(d-x)) \Big|_R^{d-R}$
- $V = \frac{Q}{2\pi\epsilon_0 l} (\ln(d-R) - \ln(R) - \ln(R) + \ln(d-R))$
- $V = \frac{Q}{\pi\epsilon_0 l} (\ln(d-R) - \ln(R))$

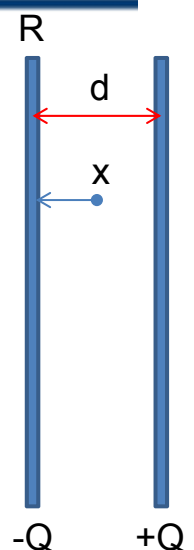

٢٦

Dr. Ahmed ElShafee, ACU : Spring 2015, Physics II

- $V = \frac{Q}{\pi \epsilon_0 l} (\ln (d - R) - \ln (R))$
- If  $d \gg R$
- $V = \frac{Q}{\pi \epsilon_0 l} (\ln (d) - \ln (R)) = \frac{Q}{\pi \epsilon_0 l} (\ln \left( \frac{d}{R} \right))$
- $C = \frac{Q}{V} = \frac{\pi \epsilon_0 l}{\ln d/r}$

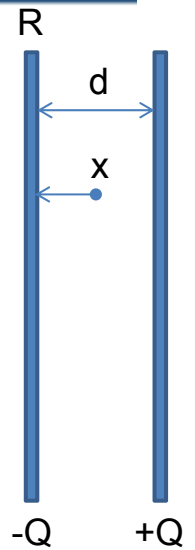

## Capacitors in Series and Parallel

- It is very often that more than one capacitor is used in an electric circuit
- We would have to learn how to compute the equivalent capacitance of certain combinations of capacitors

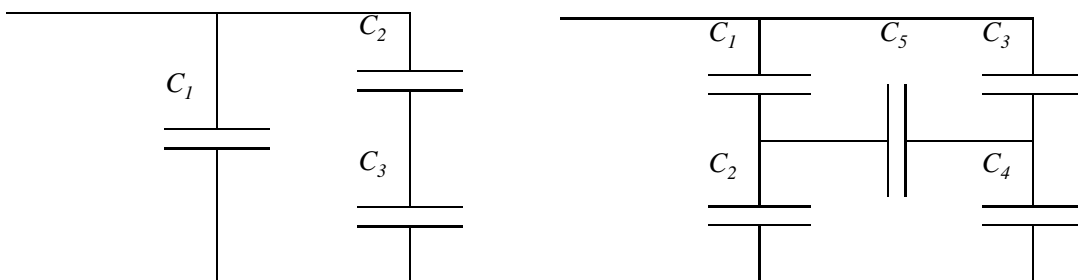

- Connecting a battery to the parallel combination of capacitors is equivalent to introducing the same potential difference for both capacitors,

- $V = V_1 = V_2$
- A total charge transferred to the system from the battery is the sum of charges of the two capacitors,
- $Q = Q_1 + Q_2$

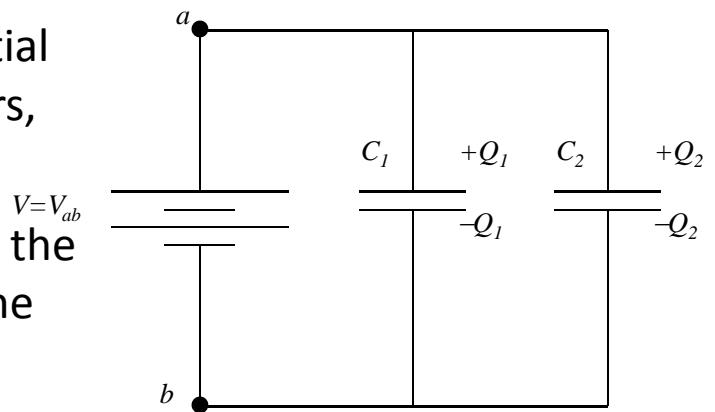

- $Q_1 = C_1 V_1$
- $Q_2 = C_2 V_2$
- $C_{eq} = \frac{Q}{V} = \frac{Q_1 + Q_2}{V} = \frac{Q_1}{v} + \frac{Q_2}{v}$
- $C_{eq} = C_1 + C_2$

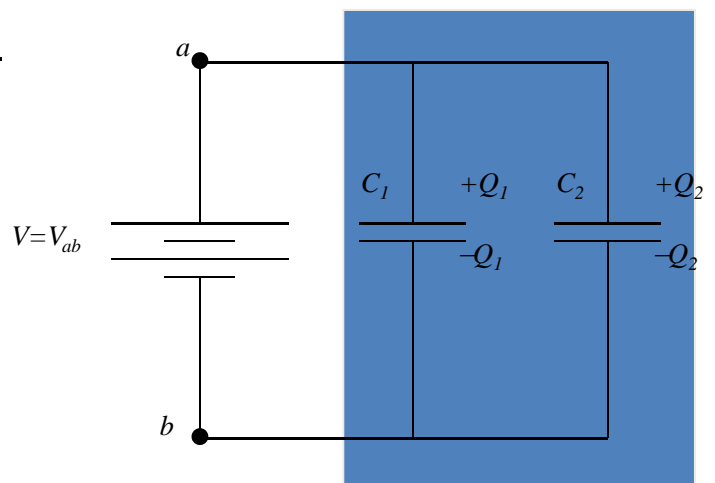



- 
- Analogous formula is true for any number of capacitors,
  - $C_{eq} = C_1 + C_2 + C_3 + \dots$
  - It follows that the equivalent capacitance of a parallel combination of capacitors is greater than any of the individual capacitors

---

## Example

- A  $3 \mu\text{F}$  capacitor and a  $6 \mu\text{F}$  capacitor are connected in parallel across an  $18 \text{ V}$  battery.
- Determine the equivalent capacitance and total charge deposited.

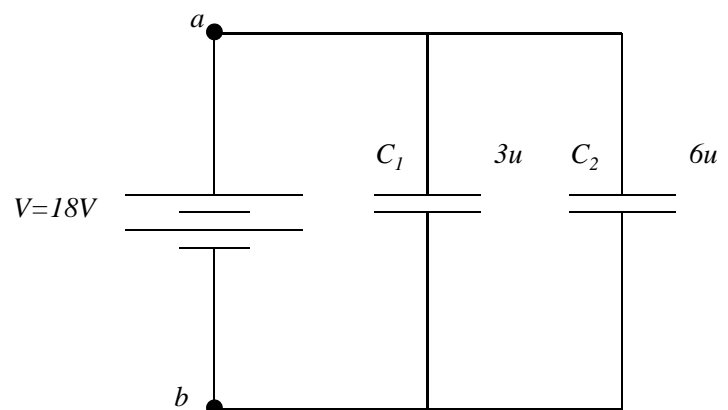

- $C_{eq} = 3 + 6 = 9 \mu F$
- $Q_{total} = C V = 9 \times 10^{-6} \times 18 = 0.162 nC$

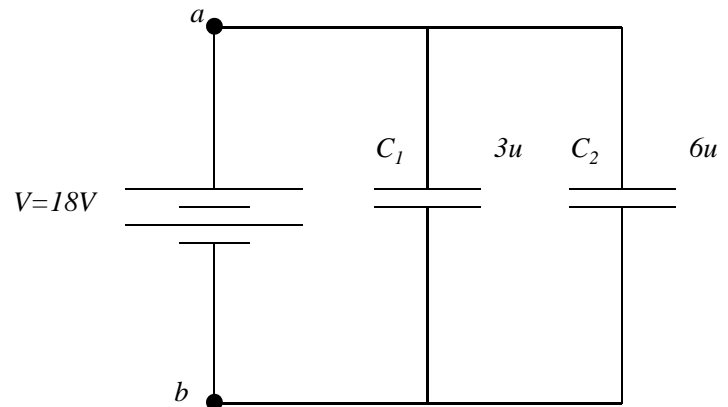

٣٣

Dr. Ahmed ElShafee, ACU : Spring 2015, Physics II

- Connecting a battery to the serial combination of capacitors is equivalent to introducing the same charge for both capacitors,
- $Q_{eq} = Q_1 = Q_2$
- A voltage induced in the system from the battery is the sum of potential differences across the individual capacitors,
- $V = V_1 + V_2$

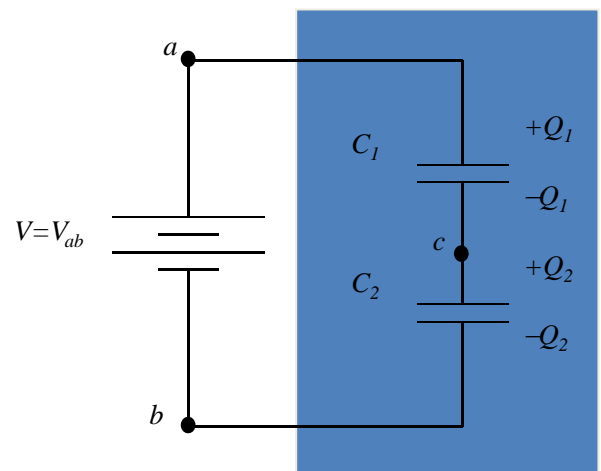

٣٤

Dr. Ahmed ElShafee, ACU : Spring 2015, Physics II

- $Q = C V$

- $\frac{1}{C_{eq}} = \frac{V}{Q} = \frac{V_1}{Q} + \frac{V_2}{Q} = \frac{1}{C_1} + \frac{1}{C_2}$

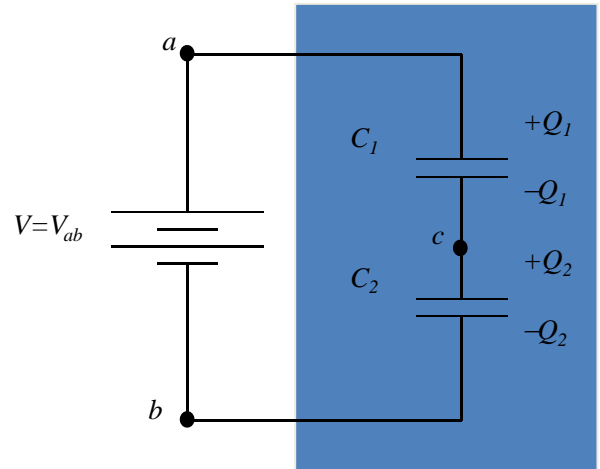

- Analogous formula is true for any number of capacitors,

- $\frac{1}{C_{eq}} = \frac{1}{c_1} + \frac{1}{c_2} + \frac{1}{c_3} + \dots$

- It follows that the equivalent capacitance of a series combination of capacitors is always less than any of the individual capacitance in the combination

# Example

- A  $3 \mu\text{F}$  capacitor and a  $6 \mu\text{F}$  capacitor are connected in series across an  $18 \text{ V}$  battery. Determine the equivalent capacitance.
- and total charge deposited.

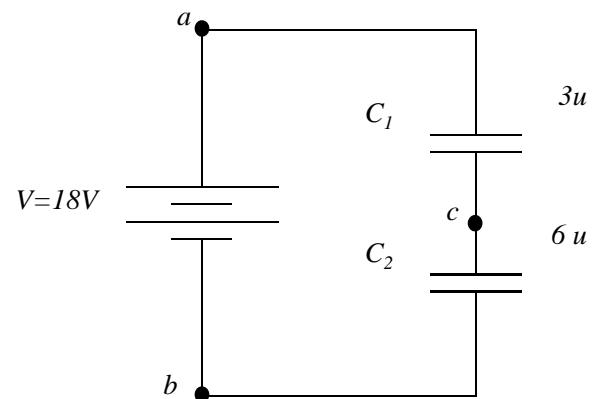

٣٧

Dr. Ahmed ElShafee, ACU : Spring 2015, Physics II

- $\frac{1}{C_{eq}} = \frac{1}{C_1} + \frac{1}{C_2} = \frac{3+6}{3 \times 6} 10^{-6} = 0.5 \times 10^6$
- $C_{eq} = 2 \mu\text{F}$
- $Q_{total} = C V = 2 \times 10^{-6} \times 18 = 36 \mu\text{C}$

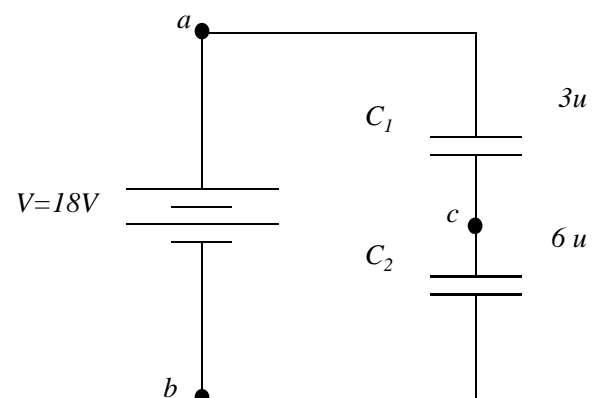

٣٨

Dr. Ahmed ElShafee, ACU : Spring 2015, Physics II

# Example

- Determine the capacitance of a single capacitor that will have the same effect as the combination shown.
- $C_1 = C_2 = C$

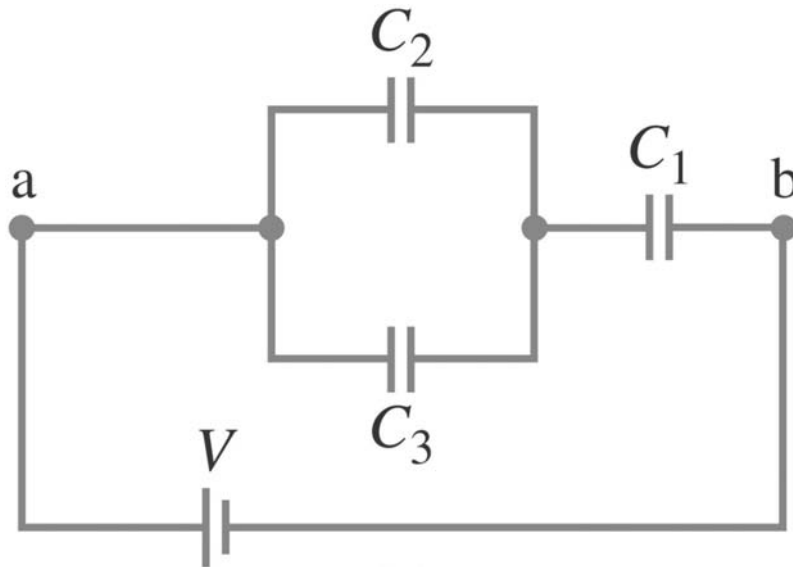

٣٩

Dr. Ahmed ElShafee, ACU : Spring 2015, Physics II

- $C_{23} = C_2 + C_3 = 2C$
- $\frac{1}{C_{123}} = \frac{1}{C_{23}} + \frac{1}{C_1}$
- $C_{123} = \frac{(C_1 \times C_{23})}{C_1 + C_{23}} = \frac{C \times 2C}{C + 2C} = \frac{2C^2}{3C} = \frac{2}{3}C$

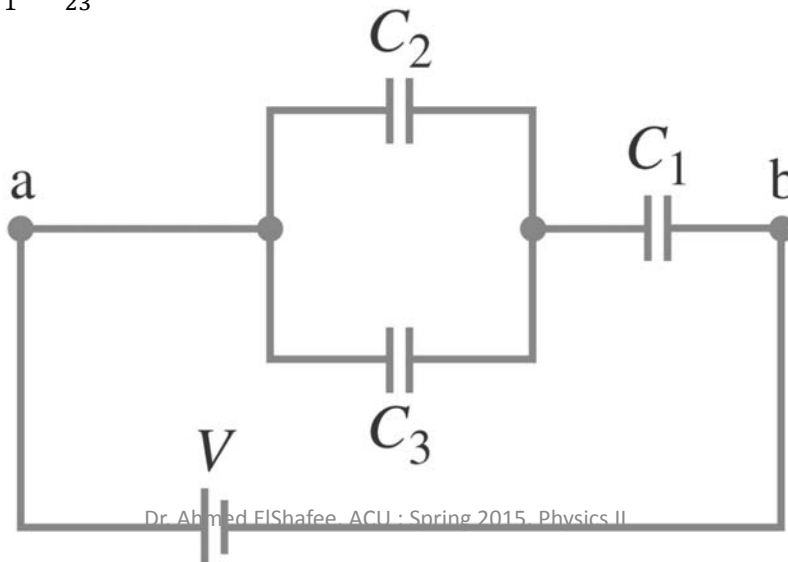

٤٠

Dr. Ahmed ElShafee, ACU : Spring 2015, Physics II

# Example

- Determine the charge on each capacitor and the voltage across each, assuming  $C = 3.0 \mu\text{F}$  and the battery voltage is  $V = 4.0 \text{ V}$ .

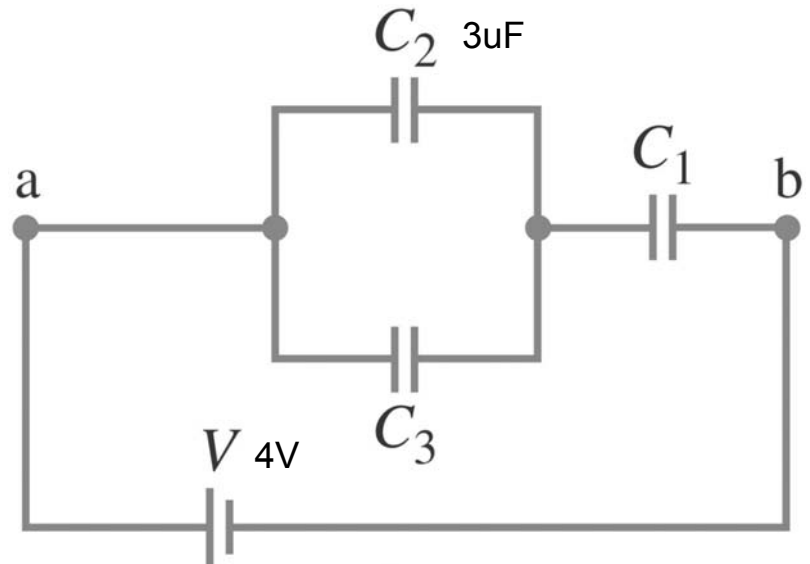

٤١

Dr. Ahmed ElShafee, ACU : Spring 2015, Physics II

- $Q_{eq} = C_{123} V_{bat} = \frac{2}{3} C V_{bat} = \frac{2}{3} \times 3 \times 4 = 8 \mu\text{C}$
- $Q_{eq} = Q_1 = Q_{23} = 8 \mu\text{C}$
- $V_{23} = V_2 = V_3$
- $\frac{Q_{23}}{C_{23}} = \frac{Q_2}{C_2} = \frac{Q_1}{C_1}$
- $\frac{8}{2C} = \frac{4}{C} = \frac{Q_2}{C} = \frac{Q_1}{C}$
- $Q_1 = Q_2 = 4 \mu\text{C}$

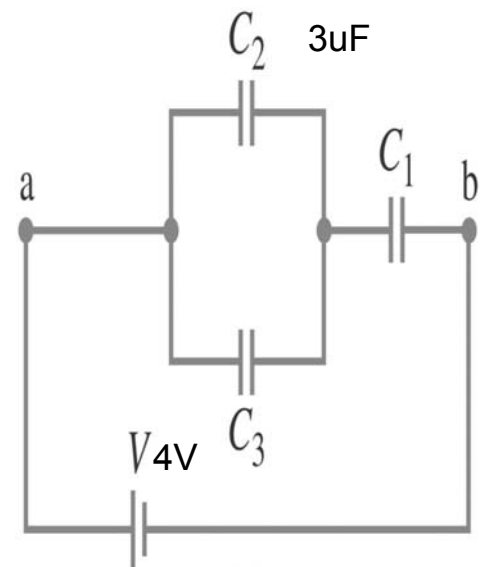

٤٢

Dr. Ahmed ElShafee, ACU : Spring 2015, Physics II

- $V_2 = V_3 = V_{23} = \frac{Q_{ea}}{C_{23}} = \frac{8 \times 10^{-6}}{6 \times 10^{-6}} = \frac{4}{3} V$
- $V_1 = V_{ba_t} - V_{23} = 4 - \frac{4}{3} = \frac{8}{3} V$

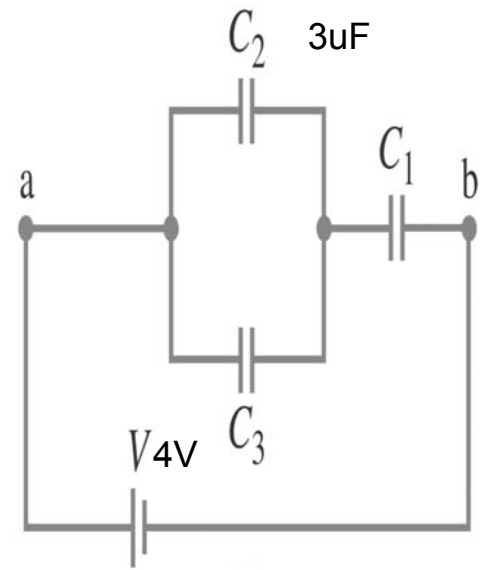

## MCQ

- What is the equivalent capacitance,  $C_{eq}$ , of the combination below?
- 1)  $C_{eq} = 3/2C$
  - 2)  $C_{eq} = 2/3C$
  - 3)  $C_{eq} = 3C$
  - 4)  $C_{eq} = 1/3C$
  - 5)  $C_{eq} = 1/2C$

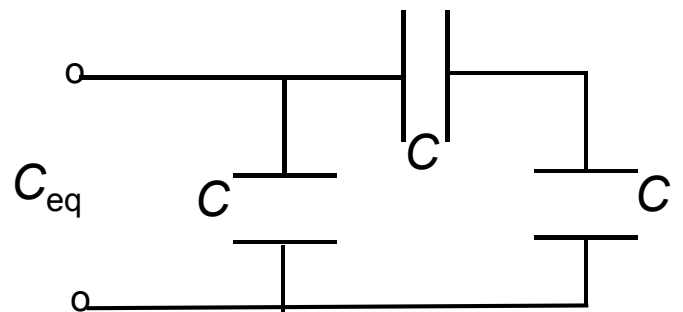



# MCQ

- What is the equivalent capacitance,  $C_{eq}$ , of the combination below?

1)  $C_{eq} = 3/2C$

2)  $C_{eq} = 2/3C$

3)  $C_{eq} = 3C$

4)  $C_{eq} = 1/3C$

5)  $C_{eq} = 1/2C$

The 2 equal capacitors in series add up as inverses, giving  $1/2C$ . These are parallel to the first one, which add up directly. Thus, the total equivalent capacitance is  $3/2C$ .

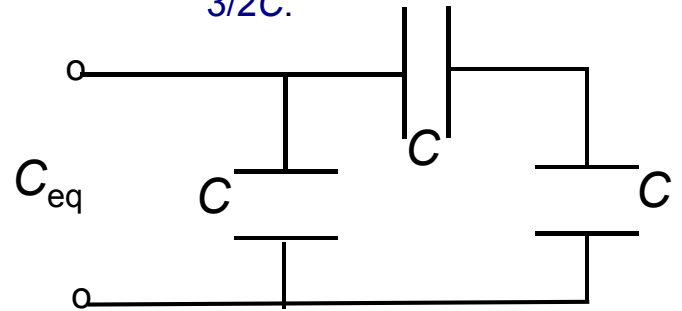

٤٠

Dr. Ahmed ElShafee, ACU : Spring 2015, Physics II

# MCQ

- How does the voltage  $V_1$  across the first capacitor ( $C_1$ ) compare to the voltage  $V_2$  across the second capacitor ( $C_2$ )?

1)  $V_1 = V_2$

2)  $V_1 > V_2$

3)  $V_1 < V_2$

4) all voltages are zero

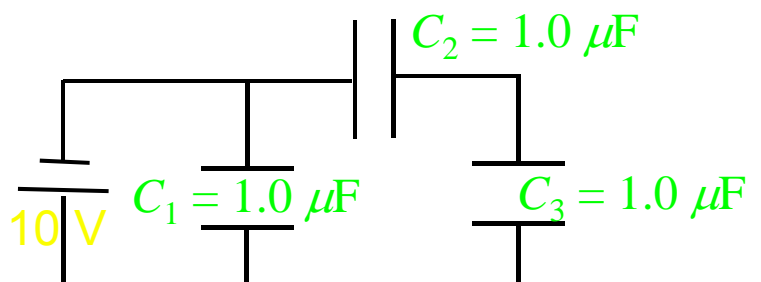

٤٦

Dr. Ahmed ElShafee, ACU : Spring 2015, Physics II

# MCQ

- How does the voltage  $V_1$  across the first capacitor ( $C_1$ ) compare to the voltage  $V_2$  across the second capacitor ( $C_2$ )?

- $V_1 = V_2$
- $V_1 \geq V_2$
- $V_1 < V_2$
- all voltages are zero

The voltage across  $C_1$  is 10 V. The combined capacitors  $C_2 + C_3$  are parallel to  $C_1$ . The voltage across  $C_2 + C_3$  is also 10 V. Since  $C_2$  and  $C_3$  are in series, their voltages add. Thus the voltage across  $C_2$  and  $C_3$  each has to be 5 V, which is less than  $V_1$ .

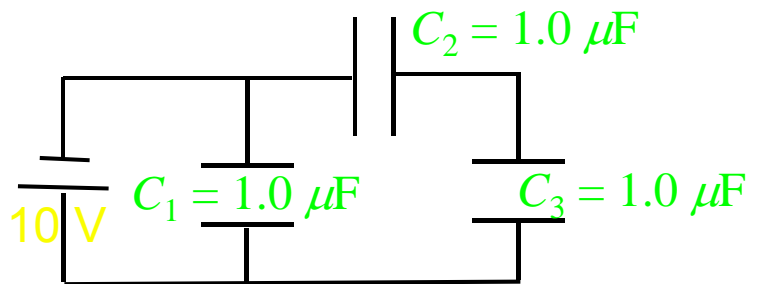

εV

Dr. Ahmed ElShafee, ACU : Spring 2015, Physics II

# Electric Energy Storage

- A charged capacitor stores electric energy; the energy stored is equal to the work done to charge the capacitor.
- Consider two sheets of charge, one positive and one negative on the surface of conductor  $b$ .

- $W = \int_0^Q V dq$
- but :  $C = \frac{q}{V}$
- $\therefore W = \int_0^Q \frac{q dq}{C} = \frac{1}{2} \frac{Q^2}{C}$

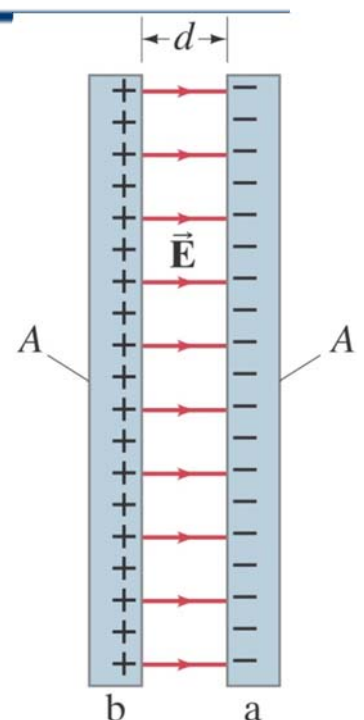

εA

Dr. Ahmed ElShafee, ACU : Spring 2015, Physics II

- Energy stored:

- $U_{stored} = \frac{1}{2} \frac{Q^2}{C}$

- *but* :  $V = \frac{Q}{C}$

- $\therefore U_{stored} = \frac{1}{2} C V^2$

- *but* :  $C = \frac{Q}{V}$

- $\therefore U_{stored} = \frac{1}{2} Q V$

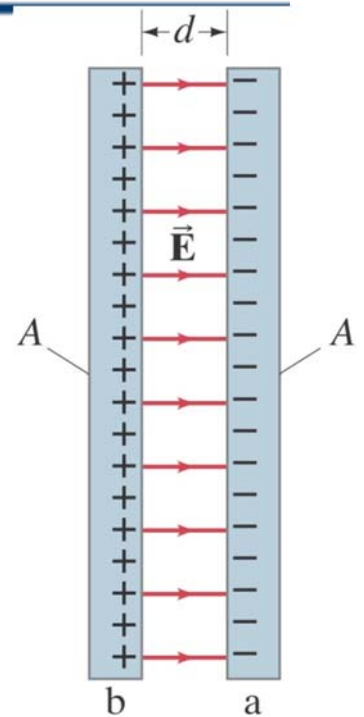

## Example

- A camera flash unit stores energy in a 150uF capacitor at 200 V.
- (a) How much electric energy can be stored?
- (b) What is the power output if nearly all this energy is released in 1 ms?

---

- $U = \frac{1}{2} C V^2 = \frac{1}{2} \times 150 \times 10^{-6} \times 200^2 = 3 \text{ J}$

- $P = \frac{U}{t} = \frac{3}{10^{-3}} = 300 \text{ W}$

---

## Dielectrics

- A dielectric is an insulator, and is characterized by a dielectric constant  $K$ .
- Capacitance of a parallel-plate capacitor filled with dielectric:

- $C = K \epsilon_0 \frac{A}{d}$

- Using the dielectric constant, we define the permittivity:

- $\epsilon = K \epsilon_0$

- Dielectric strength is the maximum field a dielectric can experience without breaking down.

**TABLE 24-1**  
**Dielectric Constants (at 20°C)**

Material	Dielectric constant $K$	Dielectric strength (V/m)
Vacuum	1.0000	
Air (1 atm)	1.0006	$3 \times 10^6$
Paraffin	2.2	$10 \times 10^6$
Polystyrene	2.6	$24 \times 10^6$
Vinyl (plastic)	2-4	$50 \times 10^6$
Paper	3.7	$15 \times 10^6$
Quartz	4.3	$8 \times 10^6$
Oil	4	$12 \times 10^6$
Glass, Pyrex	5	$14 \times 10^6$
Porcelain	6-8	$5 \times 10^6$
Mica	7	$150 \times 10^6$
Water (liquid)	80	
Strontium titanate	300	$8 \times 10^6$

٥٣

Dr. Ahmed ElShafee, ACU : Spring 2015, Physics II

- Here are two experiments where we insert and remove a dielectric from a capacitor. In the first, the capacitor is connected to a battery, so the voltage remains constant. The capacitance increases, and therefore the charge on the plates increases as well.

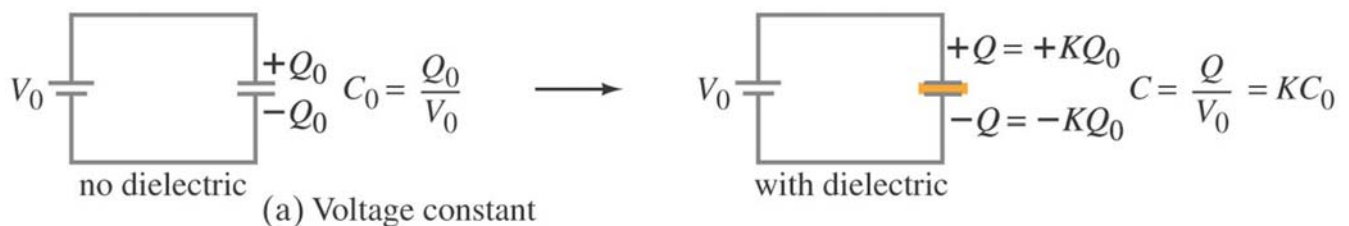

٥٤

Dr. Ahmed ElShafee, ACU : Spring 2015, Physics II

- In this second experiment, we charge a capacitor, disconnect it, and then insert the dielectric. In this case, the charge remains constant. Since the dielectric increases the capacitance, the potential across the capacitor drops.

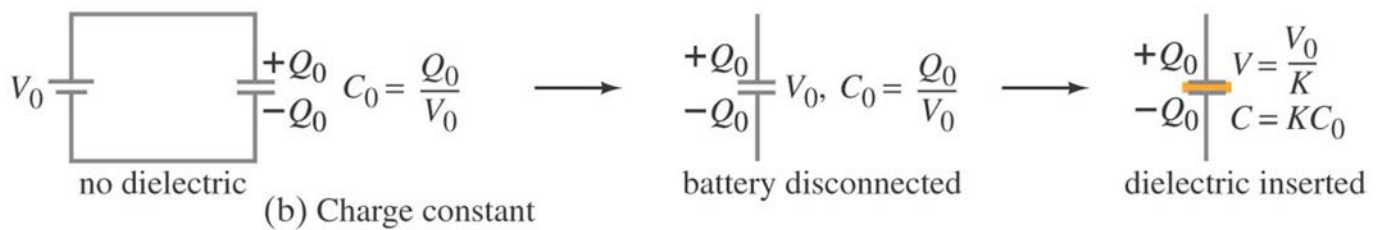

∞

Dr. Ahmed ElShafee, ACU : Spring 2015, Physics II

## Example

- A parallel-plate capacitor, filled with a dielectric with  $K = 3.4$ , is connected to a 100-V battery. After the capacitor is fully charged, the battery is disconnected. The plates have area  $A = 4.0 \text{ m}^2$  and are separated by  $d = 4.0 \text{ mm}$ .
- (a) Find the capacitance, the charge on the capacitor, the electric field strength, and the energy stored in the capacitor.
- (b) The dielectric is carefully removed, without changing the plate separation nor does any charge leave the capacitor. Find the new values of capacitance, electric field strength, voltage between the plates, and the energy stored in the capacitor.

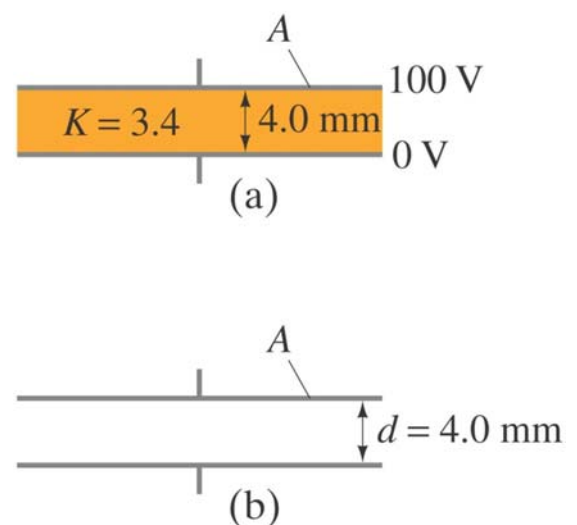

∞

Dr. Ahmed ElShafee, ACU : Spring 2015, Physics II

- Given :  $K = 3.4$

$$V_{\text{bat}} = 100\text{V}$$

$$A = 4 \text{ m}^2$$

$$d = 4 \text{ mm}$$

- $C = K \epsilon_0 \frac{A}{d} = \frac{3.4 \times 8.85 \times 10^{-12} \times 4^2}{4 \times 10^{-3}} = 3 \times 10^{-8} \text{ F}$

- $Q = C V = 3 \times 10^{-8} \times 100 = 3 \times 10^{-6} \text{ C}$

- $E = \frac{V}{d} = \frac{100}{4 \times 10^{-3}} = 25 \text{ kV/m}$

- $U = \frac{1}{2} C V^2 = \frac{1}{2} (3 \times 10^{-8}) 100^2 = 1.5 \times 10^{-4} \text{ J}$

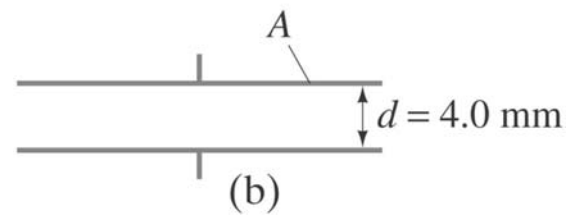
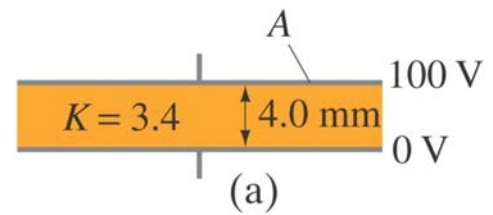

Dr. Ahmed ElShafee, ACU : Spring 2015, Physics II

- After removing dielectric, cap will be decreased by 3.4

- $C_0 = \frac{C}{K} = 3 \times \frac{10^{-8}}{3.4} = 8.8 \times 10^{-9} \text{ F}$

- $V_0 = K V = 3.4 \times 100 = 340 \text{ V}$

- $E_0 = \frac{V_0}{d} = \frac{340}{4 \times 10^{-3}} = 85 \text{ KV/m}$

- $U_0 = \frac{1}{2} C V_0^2 = \frac{1}{2} (8.8 \times 10^{-9}) (340^2) = 5.1 \times 10^{-4} \text{ J}$





Thanks,..  
See you next week (ISA),...